

### Introduction

This paper describes an inexpensive and effective current sharing technique that enhances the performance and flexibility of voltage regulator modules (VRMs) intended for VRM 9.0 applications. As will be described later, this standardization will allow for greater interoperability between products from different manufacturers and result in benefits to OEMs and end users involved in the Computer OEM marketplace.

### The Problem and Opportunity

The distributed power architecture has numerous advantages in microprocessor based systems. The point-of-load regulator in this system maintains high precision while supplying the dynamic load typical of microprocessors. The industry has evolved the point-of-load converter into the VRM complete with standard form-factor and performance specifications. High-performance desktop computers, workstations, and servers use multiple microprocessors to satisfy the computing throughput demanded of these platforms. These applications use one VRM for each microprocessor to take advantage of the modularity and economy of scale offered by the VRM.

It is desirable to power the multiple processors from common power and ground planes to improve the speed and integrity of the interconnecting signals. Tying all of the VRM outputs to common power planes requires a mechanism to insure that each VRM equally shares its portion of the load.

This paper proposes a simple current sharing technique that can meet the requirements of VRM 9.0. For illustrative purposes we focus on a dual processor architecture which includes two VRMs as shown in Figure 1.

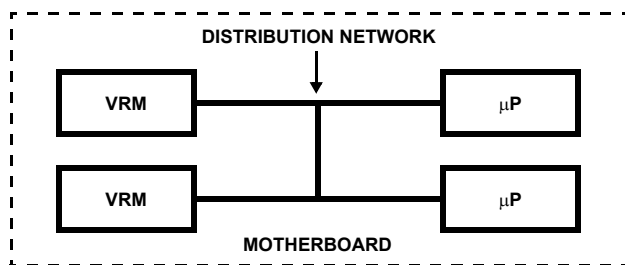

FIGURE 1. DUAL PROCESSOR/VRM ARCHITECTURE

At any given time, the two microprocessors demand different levels of current due to their processing activity and the status of their activation and stand-by states. It is desirable that the two VRMs be configured so that they share, approximately equally, the total current demand of the processors. This equalizes the load on the VRMs and results in higher reliability due to the reduced peak thermal demands and also will allow both VRMs to respond to dynamic demands from either processor, resulting in enhanced dynamic performance.

The overall goal is to have the VRMs share current so that the difference in current between the two VRMs is less than 10% of the total processor currents. But there are other criteria that are also desired. The current sharing method should:

- Be inexpensive and reliable
- Operate standalone or in configurations of up to eight parallel modules
- Configure itself automatically when the VRM is installed
- Operate with similar VRMs from different suppliers
- Operate with discrete voltage regulators (VRs) or packaged VRMs

If the above criteria can be met, VRMs from different suppliers – either packaged modules or discrete on-board solutions – will automatically share current within the 10% requirement. It will be much easier to develop second sourcing strategies and to provide field replacement and service of VRMs. We present here a methodology of accomplishing these goals, and offer it to the power and OEM communities as a solution to their common design objectives.

### Droop Regulation for Increased Dynamic Headroom

The current sharing technique presented here depends upon the droop voltage regulation characteristic designed into high performance VRMs, so we will first briefly discuss the operation and implementation of this function. Droop regulation is a technique for deliberately adding a slope to the output voltage vs. output current regulation characteristic so that additional dynamic headroom is available both at the low current and high current regions, as shown in Figure 2. This slope can be achieved either by increasing the source impedance or by means of electronic control of the regulation characteristic. The output DC voltage remains within the regulation limits over all values of load current, but is skewed to a higher value at light load and to a lower value at heavy load. When operating at light load, an increasing current load transient will generate a negative-going voltage transition, and the output voltage is now biased so that there is a maximum amount of headroom for this transient before reaching the lower regulation limit. Correspondingly, a reduction in current when operating at heavy load will generate a positive-going transient, and there is now also increased headroom to accommodate it.

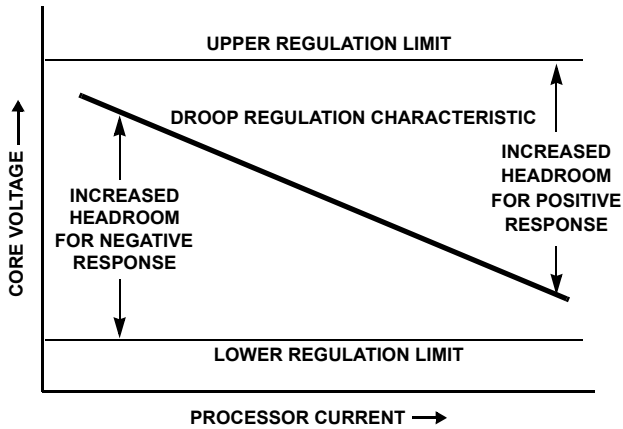

FIGURE 2. DROOP REGULATION CHARACTERISTIC

The exact implementation of the droop regulation function is dependent upon the control IC or circuitry used. For purposes of understanding, we will look at the technique utilized in the Intersil HIP6301 VRM controller. As we will see later, the current sharing approach will operate successfully even if the internal implementation of the droop function is different for different VRM suppliers.

Refer to Figure 3 for a simplified schematic of the droop regulation function in the Intersil HIP6301. For simplicity purposes we show only a two-phase VRM, but the concept is similar for additional phases.

The current in each channel of the VRM is sensed by measuring the voltage drop across  $r_{DS(ON)}$  of the lower MOSFET when it is conducting. This sensed current is then used to balance the two (or more) channel currents as indicated in the diagram. Consequently, the VRM has internal current sharing for its own channels, but no provision for current sharing with an additional VRM. The sensed channel currents are also used to control additional current sources. The outputs of these current sources will be proportional to the individual channel currents, and their sum will represent the total current output of the VRM. As can be seen from the diagram, the only DC path for these currents is the resistor  $R_{FB}$  which returns to the output,  $V_{CORE}$ . The summed channel currents, flowing through this resistor, develop a voltage drop,  $V_{DROOP}$ , which offsets the error amplifier in the direction to decrease the VRM output voltage as the output current increases. In the HIP6301, the value of  $I_{DROOP}$  that corresponds to full output current from the VRM is  $50\mu A$ . This value of current and the desired voltage droop characteristic will determine the selection of the value of  $R_{FB}$ . We will use the voltage  $V_{DROOP}$ , which is proportional to the VRM output current, as the basis of the VRM current sharing technique described below. The technique will also be compatible with other droop regulation techniques that develop a scalable voltage proportional to the VRM output current.

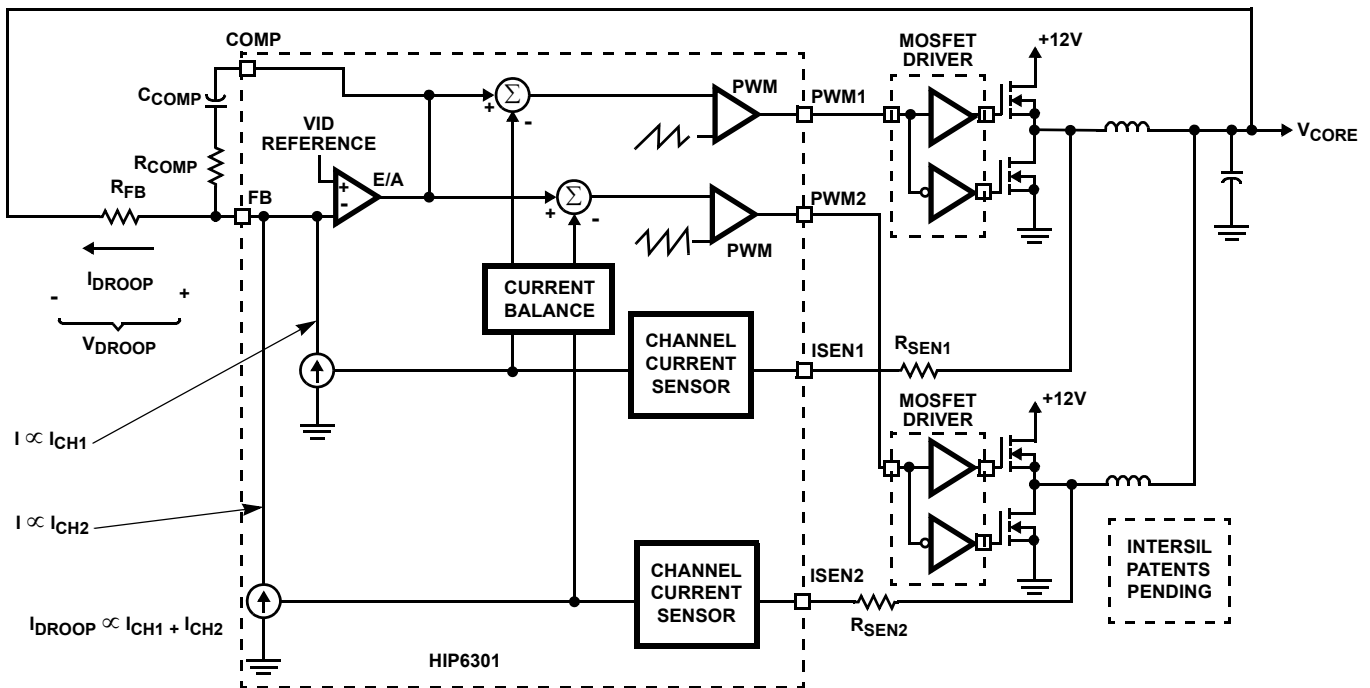

FIGURE 3. IMPLEMENTATION OF DROOP REGULATION

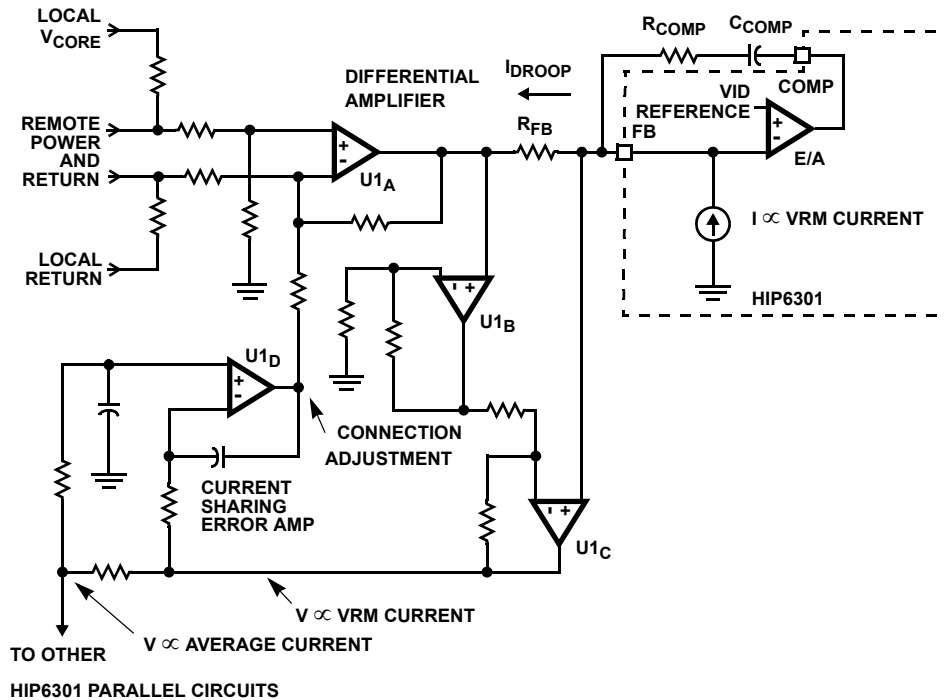

FIGURE 4. CURRENT SHARING CIRCUITRY

### Circuit Description

The circuitry used to achieve the current sharing between VRMs is shown in Figure 4. It consists of a single quad op amp, U1, along with associated small resistors and capacitors. U1<sub>A</sub> is used as a differential amplifier for the purpose of achieving differential remote sensing close to the processors. There are also local sense resistors to protect the VRM from overvoltage conditions in the event of an open sense line. The output of U1<sub>A</sub> connects to R<sub>FB</sub> at the same location as V<sub>CORE</sub> in Figure 3. I<sub>DROOP</sub> flows through R<sub>FB</sub> as described in the previous section. The voltage drop across R<sub>FB</sub>, V<sub>DROOP</sub>, is amplified by U1<sub>B</sub> and U1<sub>C</sub> to achieve a voltage that is proportional to the total output current of this VRM.

U1<sub>D</sub> is the current sharing error amplifier. The voltage developed by U1<sub>B</sub> and U1<sub>C</sub>, representing the output current of the VRM, is presented to its inverting input. This same voltage is sent through a summing resistor to the common current sharing connection to the other VRM. This node then represents the average current from both VRMs. U1<sub>D</sub> compares the VRM current with the average current of both VRMs and makes an appropriate correction to the inverting input of the differential amplifier, U1<sub>A</sub>. This correction will force both VRMs to achieve the same output current to within the specified tolerance.

If another control IC or circuit is used in place of the Intersil HIP6301, the current sharing can still function so long as the V<sub>DROOP</sub> signal is appropriately scaled to the same full current

value. If this is done, VRMs and discrete circuits from different suppliers may work together to achieve the desired current sharing performance.

Figure 5 shows the complete system implementation when two VRMs are interconnected with the current sharing technique. The circuitry dedicated to the current sharing function is labelled in the figure. Note that each VRM receives remote sensing information from the common load bus.

### Implementation and Performance

The proposed current sharing technique was implemented by Artesyn Technologies® in a prototype four phase VRM using the Intersil HIP6301 control IC. The current sharing implementation was done with one quad op-amp along with a few discrete resistors and two small capacitors, and takes up a minimal amount of additional board space on the VRM as seen in Figure 6. This minimal component count and board space, along with one signal pin on the VRM connector for current sharing, results in an economical and reliable solution.

A test set-up configured with two VRMs was used to evaluate the current sharing performance of the interconnected VRMs. The load currents on the two load connections could be varied independently via electronic loads so that the current contribution of each VRM could be measured as a function of the currents on each load.

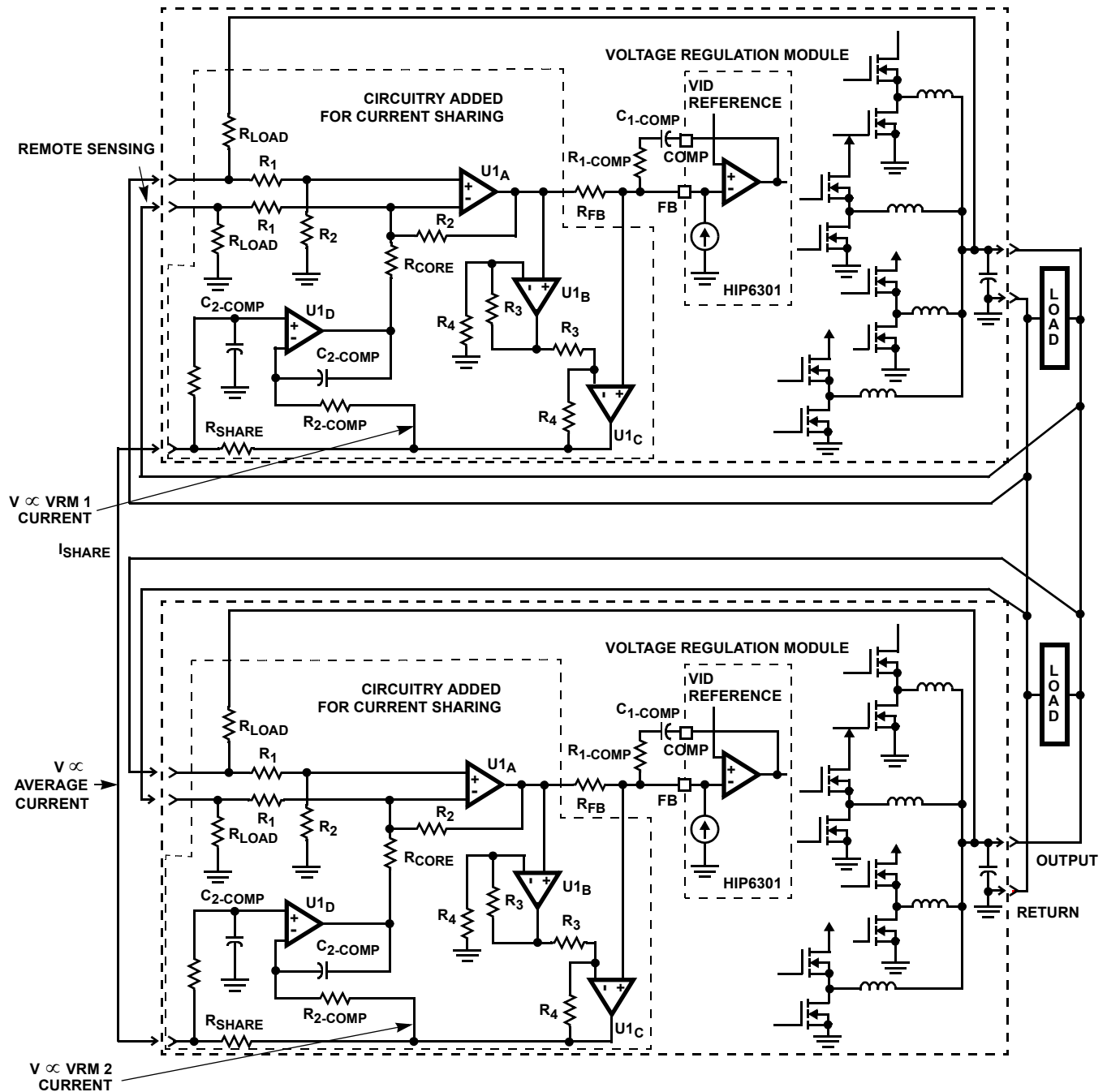
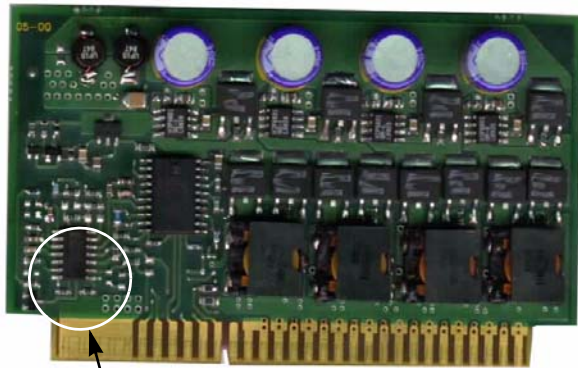

FIGURE 5. IMPLEMENTATION OF CURRENT SHARING BETWEEN VRMs

Several data points were obtained, ranging from balanced 4A loads up to a completely unbalanced load with 100A on one load and 0A on the other. The resulting current sharing performance is shown in Table 1. The percentage of current sharing is shown along with the absolute difference in current between the two VRMs. Note that, under all conditions, the current sharing is well below the 10% objective.

The contribution of the current sharing connection is graphically illustrated in Figure 7. In this test the current

sharing connection was kept open initially in a situation with a large imbalance between the VRMs. There was a load current of 45A, but the imbalance caused one VRM to sink 5A of current while the other VRM sourced 50A, 45A for the load and 5A for the first VRM. After connecting the current sharing lines, the two VRMs established equal currents of 22.5A in less than 2ms.



CURRENT SHARE CIRCUITRY

Photo Courtesy of Artesyn Technologies

FIGURE 6. PHYSICAL REALIZATION OF PROPOSED CIRCUIT

TABLE 1. CURRENT SHARING PERFORMANCE

LOAD 1 (A)	LOAD 2 (A)	VRM 1 (A)	VRM 2 (A)
4	4	3.70	4.30
8	8	7.50	8.50
0	16	7.35	8.65
30	0	16.25	13.75
30	30	28.10	31.90
0	60	27.60	32.40
50	50	47.00	53.00
0	100	46.40	53.50

**Summary**

A VRM current sharing technique has been presented that should meet the desired technical requirements and be very attractive for both power module suppliers and OEMs in the computing marketplace. Standardizing upon a common approach as suggested here provides the advantage of interoperability between various vendors greatly simplifying the logistics of multi-sourcing.

It is the intent of Intersil to make this concept and the resulting circuits freely and openly available to the power module community without licensing or royalties.

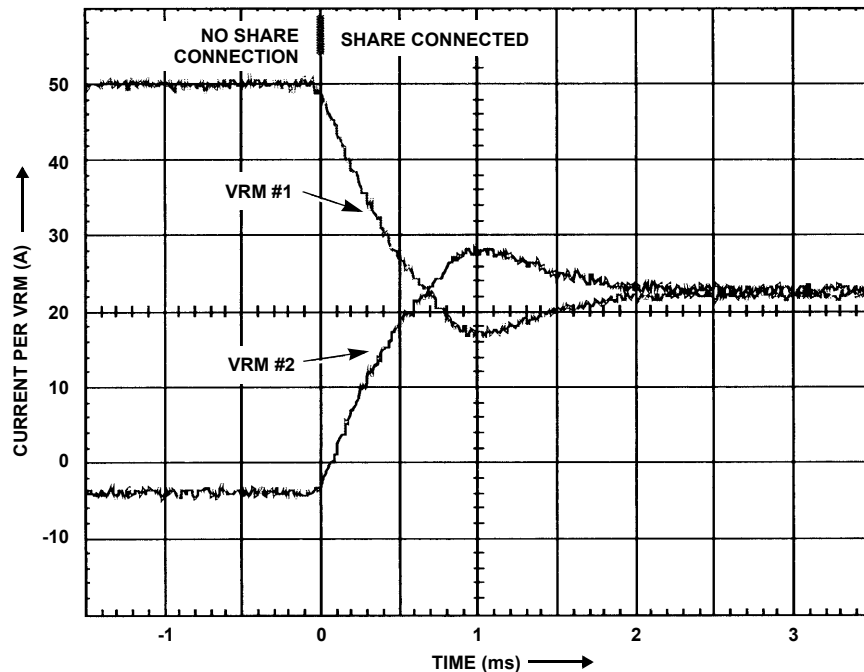

FIGURE 7. CURRENT SHARING PERFORMANCE

## Notice

1. Descriptions of circuits, software and other related information in this document are provided only to illustrate the operation of semiconductor products and application examples. You are fully responsible for the incorporation or any other use of the circuits, software, and information in the design of your product or system. Renesas Electronics disclaims any and all liability for any losses and damages incurred by you or third parties arising from the use of these circuits, software, or information.
2. Renesas Electronics hereby expressly disclaims any warranties against and liability for infringement or any other claims involving patents, copyrights, or other intellectual property rights of third parties, by or arising from the use of Renesas Electronics products or technical information described in this document, including but not limited to, the product data, drawings, charts, programs, algorithms, and application examples.
3. No license, express, implied or otherwise, is granted hereby under any patents, copyrights or other intellectual property rights of Renesas Electronics or others.
4. You shall not alter, modify, copy, or reverse engineer any Renesas Electronics product, whether in whole or in part. Renesas Electronics disclaims any and all liability for any losses or damages incurred by you or third parties arising from such alteration, modification, copying or reverse engineering.
5. Renesas Electronics products are classified according to the following two quality grades: "Standard" and "High Quality". The intended applications for each Renesas Electronics product depends on the product's quality grade, as indicated below.  
"Standard": Computers; office equipment; communications equipment; test and measurement equipment; audio and visual equipment; home electronic appliances; machine tools; personal electronic equipment; industrial robots; etc.  
"High Quality": Transportation equipment (automobiles, trains, ships, etc.); traffic control (traffic lights); large-scale communication equipment; key financial terminal systems; safety control equipment; etc.  
Unless expressly designated as a high reliability product or a product for harsh environments in a Renesas Electronics data sheet or other Renesas Electronics document, Renesas Electronics products are not intended or authorized for use in products or systems that may pose a direct threat to human life or bodily injury (artificial life support devices or systems; surgical implantations; etc.), or may cause serious property damage (space system; undersea repeaters; nuclear power control systems; aircraft control systems; key plant systems; military equipment; etc.). Renesas Electronics disclaims any and all liability for any damages or losses incurred by you or any third parties arising from the use of any Renesas Electronics product that is inconsistent with any Renesas Electronics data sheet, user's manual or other Renesas Electronics document.
6. When using Renesas Electronics products, refer to the latest product information (data sheets, user's manuals, application notes, "General Notes for Handling and Using Semiconductor Devices" in the reliability handbook, etc.), and ensure that usage conditions are within the ranges specified by Renesas Electronics with respect to maximum ratings, operating power supply voltage range, heat dissipation characteristics, installation, etc. Renesas Electronics disclaims any and all liability for any malfunctions, failure or accident arising out of the use of Renesas Electronics products outside of such specified ranges.
7. Although Renesas Electronics endeavors to improve the quality and reliability of Renesas Electronics products, semiconductor products have specific characteristics, such as the occurrence of failure at a certain rate and malfunctions under certain use conditions. Unless designated as a high reliability product or a product for harsh environments in a Renesas Electronics data sheet or other Renesas Electronics document, Renesas Electronics products are not subject to radiation resistance design. You are responsible for implementing safety measures to guard against the possibility of bodily injury, injury or damage caused by fire, and/or danger to the public in the event of a failure or malfunction of Renesas Electronics products, such as safety design for hardware and software, including but not limited to redundancy, fire control and malfunction prevention, appropriate treatment for aging degradation or any other appropriate measures. Because the evaluation of microcomputer software alone is very difficult and impractical, you are responsible for evaluating the safety of the final products or systems manufactured by you.
8. Please contact a Renesas Electronics sales office for details as to environmental matters such as the environmental compatibility of each Renesas Electronics product. You are responsible for carefully and sufficiently investigating applicable laws and regulations that regulate the inclusion or use of controlled substances, including without limitation, the EU RoHS Directive, and using Renesas Electronics products in compliance with all these applicable laws and regulations. Renesas Electronics disclaims any and all liability for damages or losses occurring as a result of your noncompliance with applicable laws and regulations.
9. Renesas Electronics products and technologies shall not be used for or incorporated into any products or systems whose manufacture, use, or sale is prohibited under any applicable domestic or foreign laws or regulations. You shall comply with any applicable export control laws and regulations promulgated and administered by the governments of any countries asserting jurisdiction over the parties or transactions.
10. It is the responsibility of the buyer or distributor of Renesas Electronics products, or any other party who distributes, disposes of, or otherwise sells or transfers the product to a third party, to notify such third party in advance of the contents and conditions set forth in this document.
11. This document shall not be reprinted, reproduced or duplicated in any form, in whole or in part, without prior written consent of Renesas Electronics.
12. Please contact a Renesas Electronics sales office if you have any questions regarding the information contained in this document or Renesas Electronics products.  
(Note 1) "Renesas Electronics" as used in this document means Renesas Electronics Corporation and also includes its directly or indirectly controlled subsidiaries.  
(Note 2) "Renesas Electronics product(s)" means any product developed or manufactured by or for Renesas Electronics.

(Rev.4.0-1 November 2017)



### SALES OFFICES

Renesas Electronics Corporation

<http://www.renesas.com>

Refer to "<http://www.renesas.com/>" for the latest and detailed information.

**Renesas Electronics America Inc.**  
1001 Murphy Ranch Road, Milpitas, CA 95035, U.S.A.  
Tel: +1-408-432-8888, Fax: +1-408-434-5351

**Renesas Electronics Canada Limited**  
9251 Yonge Street, Suite 8309 Richmond Hill, Ontario Canada L4C 9T3  
Tel: +1-905-237-2004

**Renesas Electronics Europe Limited**  
Dukes Meadow, Millboard Road, Bourne End, Buckinghamshire, SL8 5FH, U.K.  
Tel: +44-1628-651-700, Fax: +44-1628-651-804

**Renesas Electronics Europe GmbH**  
Arcadiastrasse 10, 40472 Düsseldorf, Germany  
Tel: +49-211-6503-0, Fax: +49-211-6503-1327

**Renesas Electronics (China) Co., Ltd.**  
Room 1709 Quantum Plaza, No.27 ZhichunLu, Haidian District, Beijing, 100191 P. R. China  
Tel: +86-10-8235-1155, Fax: +86-10-8235-7679

**Renesas Electronics (Shanghai) Co., Ltd.**  
Unit 301, Tower A, Central Towers, 555 Langao Road, Putuo District, Shanghai, 200333 P. R. China  
Tel: +86-21-2226-0888, Fax: +86-21-2226-0999

**Renesas Electronics Hong Kong Limited**  
Unit 1601-1611, 16/F., Tower 2, Grand Century Place, 193 Prince Edward Road West, Mongkok, Kowloon, Hong Kong  
Tel: +852-2265-6688, Fax: +852-2886-9022

**Renesas Electronics Taiwan Co., Ltd.**  
13F, No. 363, Fu Shing North Road, Taipei 10543, Taiwan  
Tel: +886-2-8175-9600, Fax: +886-2-8175-9670

**Renesas Electronics Singapore Pte. Ltd.**  
80 Bendemeer Road, Unit #06-02 Hyflux Innovation Centre, Singapore 339949  
Tel: +65-6213-0200, Fax: +65-6213-0300

**Renesas Electronics Malaysia Sdn.Bhd.**  
Unit 1207, Block B, Menara Amcorp, Amcorp Trade Centre, No. 18, Jln Persiaran Barat, 46050 Petaling Jaya, Selangor Darul Ehsan, Malaysia  
Tel: +60-3-7955-9390, Fax: +60-3-7955-9510

**Renesas Electronics India Pvt. Ltd.**  
No.777C, 100 Feet Road, HAL 2nd Stage, Indiranagar, Bangalore 560 038, India  
Tel: +91-80-67208700, Fax: +91-80-67208777

**Renesas Electronics Korea Co., Ltd.**  
17F, KAMCO Yangjae Tower, 262, Gangnam-daero, Gangnam-gu, Seoul, 06265 Korea  
Tel: +82-2-558-3737, Fax: +82-2-558-5338